

## Digital Panel Counter Model DT-6CG

## Instruction Manual



The Shimpo model DT-6CG panel mount counter is a six/five digit LED microprocessor-controlled, fully programmable unit with an automatic multiplier that can count up or down at a very rapid rate. With the addition of the PS (preset) module, the DT-6CG can also be used as a "batch" counter/controller to count and display groups of articles rather than units alone.

### Features

- Mounts easily — no brackets, screws or any other hardware needed.
- Accepts voltages from 85 to 264VAC.
- Large 6-digit LED display.
- 10-year EEPROM memory back-up.
- Scalable.
- Accepts modules:
  - COP-BC (BCD output)
  - DOP-SD (RS232 output)
  - COP-PS (preset)
  - COP-EX (external thumb wheel)
  - DOP-PO (parallel output)

### Operational Precautions

- If the unit is used in a caustic environment, we suggest you use an NEMA 4X enclosure.
- Try to keep unit free of vibration and shock.
- When installing unit, keep power and sensor wires separate. Tie cable shield to terminal E (earth ground).
- After inserting wires, tighten terminal screws securely.

### Parts and Functions

#### Front Panel

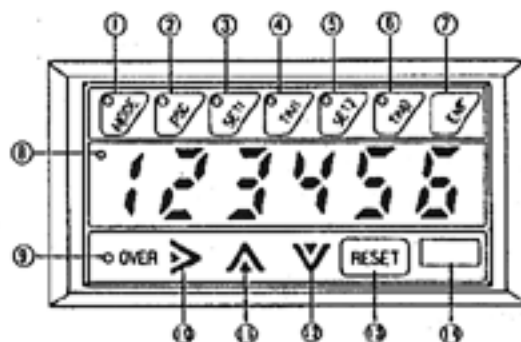

- |                      |                      |
|----------------------|----------------------|
| 1 Mode key           | 8 Minus display lamp |
| 2 Prescale key       | 9 Over lamp          |
| 3 Primary set key    | 10 Shift key         |
| 4 Primary time key   | 11 Increment key     |
| 5 Secondary set key  | 12 Decrement key     |
| 6 Secondary time key | 13 Reset key         |
| 7 Enter key          | 14 Unit decal        |

*Note: Keys 3 through 6 will only function with the COP-PS module.*

## Back Panel

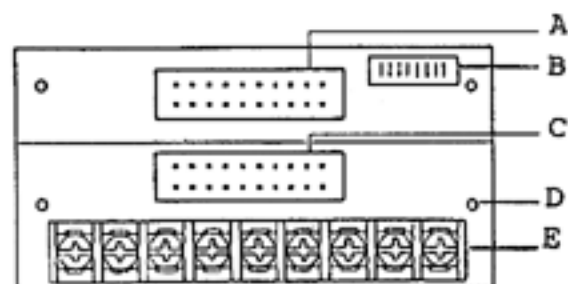

- A Connector for mounting additional module
- B Dip Switch (SW1)
- C Connector for mounting additional module
- D Screw holes for modules
- E Terminal strip

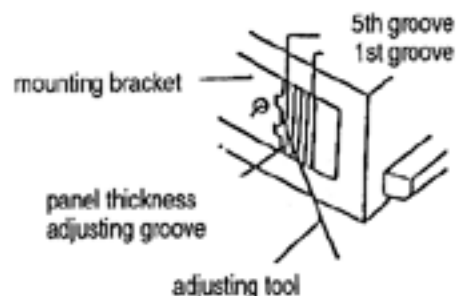

### Mounting Bracket Thickness

- 1.2 - 1.6mm
- 1.8 - 2.5mm
- 2.8 - 3.6mm
- 4.0 - 4.5mm
- 5.0mm

### Adjustment Groove

- 5th groove
- 4th groove
- 3rd groove
- 2nd groove
- 1st groove

## Installation and Dimensions

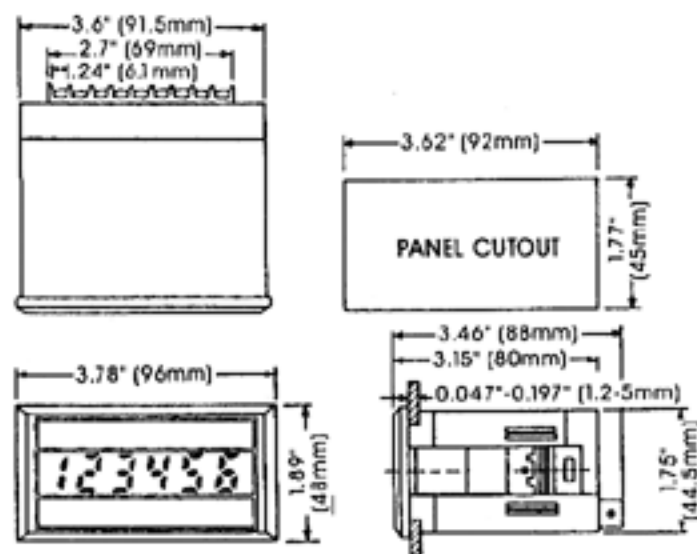

Panel cut-away thickness: 1.2 - 5mm

Panel thickness: 1.2 - 5mm

## Mounting Unit

Our 1/8 DIN case design eliminates the need for brackets and screws for installation. With the counter in a level position, insert it into the panel cutout. Gently push the face of the unit until the front bezel locks into place. If the counter case is loose, adjust the integral bracket with the enclosed tool.

## Removing Unit

From the rear of the counter alternately push the unit from left to right. This will free it for easy removal.

## Connections

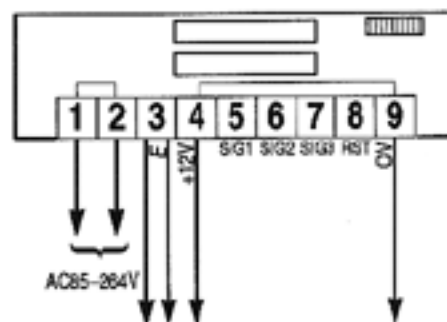

- 1&2 Line voltage input — AC voltage must be between 85 and 264 volts.
- 3 Earth ground — connect all cable shielding to this terminal.
- 4 12VDC 100 mA max — this sensor power supply is for any sensor that requires external power.
- 5 Signal 1 — pulse input.
- 6 Signal 2 — pulse or command input.
- 7 Signal 3 — count inhibit or display hold.
- 8 External reset input.
- 9 OV signal ground.

## DIP Switch Settings (SW1)

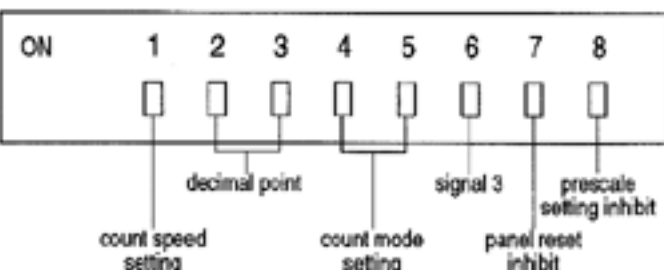

When DIP switch settings have been completed, press the reset button while the power is on and the unit is not counting. This will enable the new settings.

### Setting 1: Count Speed Setting

Set switch to:

- OFF: If input is  $>20\text{Hz}$ .
- ON: If input is  $\leq 20\text{Hz}$ .

### Settings 2 and 3: Decimal Point Setting

Set switches 2 and 3 in the following combinations for the desired decimal position:

Switch 2	Switch 3	Decimal point
OFF	OFF	0
ON	OFF	0.0
OFF	ON	0.00
ON	ON	0.000

### Settings 4 and 5: Count Mode Setting

Set switches 4 and 5 in the following combinations for these modes:

Mode                      Switch 4    Switch 5

1 – Up/down counting    OFF        OFF

Ex: If pulses are inputted into SIG1, up count.

    If pulses are inputted into SIG2, down count.

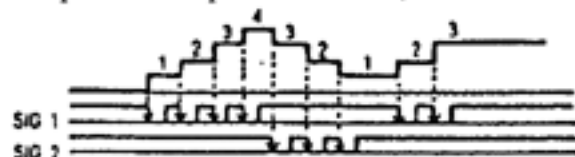

Mode                      Switch 4    Switch 5

2 – Command mode            ON        OFF

Ex: If SIG2 is high and SIG1 is active, up count.

    If SIG2 is low and SIG1 is active, down count.

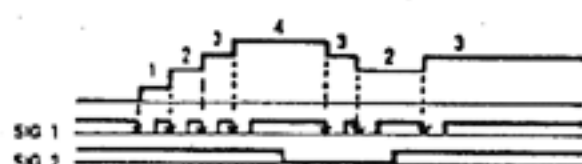

Mode                      Switch 4    Switch 5

3 – 90 degree phase difference mode            OFF        ON

Ex: If SIG1 leads SIG2 by 90 degrees, up count.

    If SIG1 lags SIG2 by 90 degrees, down count.

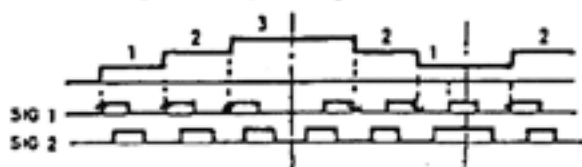

### Setting 6: SIG3 Mode Setting

When set to:

- OFF: SIG3 works as a count inhibit.
- ON: SIG3 works as a display hold signal.

### Setting 7: Panel Reset Prohibit

When set to:

- OFF: Reset key on front panel is operational.
- ON: Reset key operation on front panel is inhibited.

### Setting 8: Prescale Inhibit

When set to:

- OFF: Prescale inhibit is off.
- ON: Prescale inhibit is on.

### Reset Key

Pressing the reset key will make the counting value zero and enable new switch settings.

### External Reset

This enables the counter to be reset from a remote location using the terminals in the rear of the counter.

### Overscale

When the measuring value passes 999,999 the over lamp will turn on. If the measuring value passes 1,999,999 error message *E-10* will be displayed.

### Minus Display

This LED acts as a minus sign when all six digits are used on the display.

## Determining Prescale Value

Here's how to determine the prescale value:

Conditions: roller diameter — 0.3m  
rotary pulse generator — 60ppr

Display to show distance in meters:

1. Number of pulses per 1 revolution = 60
2. Feeding distance for 1 revolution of roller =  $0.3 \times 3.1415 = .94245\text{m}$
3. Set counter to display 942.5m at 60,000 pulses.  
 $P$  (number of pulses) = 60,000  $D$  (display) = 942.5

For a 6-digit counter:  $0.01 \leq d/p \leq 100$

For a 5-digit counter:  $0.001 \leq d/p < 0.01$

Setting the prescale value to the above example requires the following steps:

1. Set switch 2 on and 3 off. Press reset.
2. Press mode. Mode, prescale and 5th digit will flash.
3. Press increment, shift and decrement keys to adjust the number of pulses.
4. Press PSC.
5. Press increment, shift and decrement keys to adjust the display value.
6. Press ENT to set the display/pulses ratio into memory.

Note: If the  $d/p$  ratio is beyond the specified range, E-01 will be displayed.

To review the prescale value, press PSC. The pulse and display values will be displayed for two seconds each.

## Sensors

Shimpo offers a large selection of sensors to be used with the DT-6CG. The chart below shows the sensor to use that will best meet your application needs. Please call us for more information.

Sensor	Type	Freq. of RPM Range	Terminal Connections (count)	Temp. Range
BI2-S12	Proximity Switch	0 to 2kHz	4,5,9(up) 4,6,9(down)	-13° F to +158° F
SE-G	Proximity Switch	0 to 8kHz	4,5,9(up) 4,6,9(down)	-4° F to +158° F
RS220H	Retro-Reflective	0 to 500Hz	4,5,9(up) 4,6,9(down)	+14° F to +140° F
MCS-625	Retro-Reflective	0 to 250Hz	4,5,9(up) 4,6,9(down)	-22° F to +120° F
RE1B-60C	Rotary Pulse Generator	0 to 5000rpm	4,5,9(up) 4,6,9(down)	+14° F to +122° F
RE2B-30C*	Rotary Pulse Generator	0 to 5000rpm	4,5,9(up) 4,6,9(down)	+14° F to +122° F
Switch Closure	Relay or Solenoid	< 20Hz	5,9(up) 6,9(down)	

\*Can be used as a quadrature encoder directly with count mode 3

## Error Codes

Error Code	Situation	What to do
E-01	Prescale value is beyond specifications	Press reset and change the prescale value
E-10	Count has exceeded +/- 1,999,999	Press reset
E-12	Memory readout error	Press reset
E-13	Memory writing error	Press reset
C-01	Decimal point setting is changed	Press the mode key and match decimal with the pre-scale value

## Specifications

Function	
Counter type	Bidirectional (up/down)
Display range	-999,999 to +999,999
Measuring range	-1,999,999 to +1,999,999 if display to number of pulses ratio is between 0.01 and 100. If display to number of pulses is between 0.001 and 0.01, then range is -99,999.9 to +99,999.9
Display	6-digit, 7-segment LED, 0.56" high (14.2mm)
Frequency (input)	10kHz square wave, 20Hz switching contacts
Decimal point	Selectable (0, 0.0, 0.00, 0.000)
Memory	EEPROM, 10-year back-up
Voltage output	12VDC +/-5% (100mA max.) to power sensors
Applicable sensors	Rotary pulse generator, magnetic pick-up, proximity switch, retro-reflective
Ambient temperature	32° -113° F (0-45° C)
Power consumption	2W
Voltage requirement	85-264VAC (60/50Hz)
Dimensions	3.46"L x 1.88"H x 3.78"W; (88L x 48H x 96W)mm; 1/8 DIN cut out
Input signal: amplitude	High: 4.5-30VDC, Low: 0-1VDC, 10ma (sink)
pulse width	50 $\mu$ s minimum
Weight	0.55 lbs. (250g)



# SHIMPO

AMERICA CORPORATION  
3500 DEVON AVENUE, LINCOLNWOOD, IL 60659  
Telephone: (708) 679-6765 Fax: (708) 679-5058